

HIGH PERFORMANCE PV-BATTERY HYBRID SYSTEM WITH MULTILEVEL INVERTER FED TO INDUCTION MOTOR DRIVE AND TOTAL HARMONIC DISTORTION ANALYSIS

N.Triveni¹, Dr.K.Ravichandrudu² and P. Yohan Babu³

¹PG Student, Krishnaveni Engineering College for women, Narasaraopet, Andhra Pradesh, India

Email: triveni.nelakurthi@gmail.com

²Professor, Krishnaveni Engineering College for women, Narasaraopet, Andhra Pradesh, India

Email: kattaravieeee@gmail.com

³Assistant Professor, Krishnaveni Engineering College for women, Narasaraopet, Andhra Pradesh, India

Email: yohanchowdary@gmail.com

ABSTRACT

This paper presents the control of a multilevel inverter supplied by a Photovoltaic (PV) panel and a batteries bank. It is well known that the power quality of multilevel inverter signals depends on their number of levels. However, the question that arises is whether there is a limit beyond which it is not necessary to increase the number of level. This question is addressed in this paper seven -level converters are studied. The harmonics content of the output signals are analyzed. A simplified Pulse Width Modulation (SPWM) method for a multilevel inverter that supplied an induction motor is developed. The controller equations are such that the SPWM pulses are generated automatically for any number of levels. The effectiveness of the propose method is evaluated in simulation. Matlab®/Simulink is used to implement the control algorithm and simulate the system.

Keywords: Induction motor, multilevel inverter, Multilevel SPWM, THD

INTRODUCTION

Nowadays, the industry requires power equipment increasingly high, in the megawatt range. The rapid evolutions of semiconductor devices manufacturing technologies and the designer's orientation have enabled the development of new structures of converters (inverters) with a great performance compared to conventional structures. So, these new technologies of semiconductor are more suited to high power applications and they enable the design of multilevel inverters. The constraints due to commutation phenomena are also reduced and each component supports a much smaller fraction of the DC-bus voltage when

the number of levels is higher. For this reason, the switches support more high reverse voltages in high-power applications and the converter output signals are with good spectral qualities.

Thus, the using of this type of inverter, associated with a judicious control of power components, allows deleting some harmonics [1]. Among the control algorithms proposed in the literature in this field [2-3-4], the SPWM, appears most promising. It offers great flexibility in optimizing the design and it is well suited for digital implementation. It also helps to maximize the available power. The main advantage of multilevel inverters is that the output voltage can be generated with a low harmonics. Thus it is admitted that the harmonics decrease proportionately to the inverter level. For these reasons, the multilevel inverters are preferred for high power applications [5-6]. However, there is no shortage of disadvantages. Their control is much more complex and the techniques are still not widely used in industry [7-8].

In this paper, modelling and simulation of a multilevel inverter using Neutral-Point-Clamped (NPC) inverters have been performed with motor load using Simulink/ MATLAB program.

In the first section multilevel inverter control strategies are presented before to detail a study of *seven-level* inverter in the second section. Total Harmonic Distortion (THD) is discussed in the third section. The aim is to highlight the limit at which the multilevel inverters are no longer effective in reducing output voltage harmonics.

Photovoltaic and Battery Energy Generation

Photovoltaic (PV) systems are stand-alone power generators that have good environmental footprints. The modeling and the Maximum Power Point Tracking (MPPT) control strategy for a PV system are developed in [9]. In the latter, the control strategy that is presented is based only on the measurement of the PV current to track the maximum power. A batteries bank is added to the DC-bus to ensure the energetic autonomy of the system.

A Proportional-Integral (PI) controller is used to regulate the DC-bus voltage ___ at a constant value. As a consequence the batteries compensate for the difference between the power supplied by the PV system and the power needed by the induction motor. The batteries are charged when the PV power exceeds the motor demand [10].

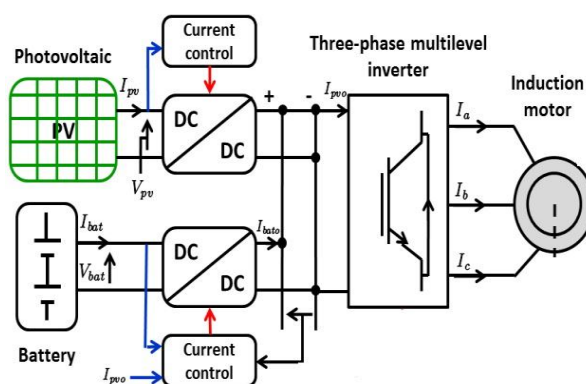

Figure 1: Induction motor driven by PV-batteries standalone system using a controlled multilevel inverter

Multilevel Inverter Control Strategies

The Three Level inverter Control Strategy

Fig. 2 shows a three-phase three-level inverter. It has three arms. Each arm has four switches. Every switch is connected in antiparallel with a diode. This paragraph describes the operation of one of the legs shown at Fig. 3. The voltage V_{ao} between the phase "a" and the neutral point O is defined entirely by the switches position (0 'open' or 1 'closed'). Switch sets [S11, S13], and [S12, S14] have complementary positions. When [S11, S13], are open [S12, S14] are closed. The *three-level* NPC inverter is mostly used [10] for medium-voltage high-power applications.

In this converter, the number of commutation sequences (Seq) is equal to $2^4 = 16$., where 4 stands for the number of switches per arm and 2 is the number of state per switch (0, 1). V_{dc} is the DC-bus voltage. Only three commutation sequences are possible. They are represented at Table 1. Fig. 3 shows the configurations of the inverter's arm which correspond to the three possible commutation sequences:

- Sequence 1: S11, S12 conduct and S13, S14 open (Fig. 3.a). $V_{ao} = +V_{dc}/2$.
- Sequence 2: S12, S13 conduct and S11, S14 open (Fig. 3.b). $V_{ao} = 0$.
- Sequence 3: S13, S14 conduct and S11, S12 open (Fig. 3.c). $V_{ao} = -V_{dc}/2$.

Sequences 1, 2 and 3 are applied in this order periodically.

A pulse width modulation is used to control the switches. Consider Fig. 3 and Fig. 4, the reference voltage V_{ra} is compared to the positive and negative sawtooth carrier V_{cx} and V_{cy} respectively. The comparator output is sent to the switches (Insulated Gate Bipolar Transistor or IGBT) to generate the machine phase voltage.

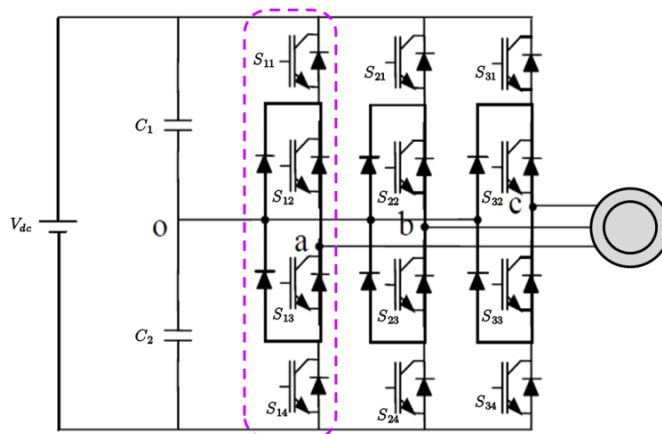

Figure 2: Three-level three phase inverter

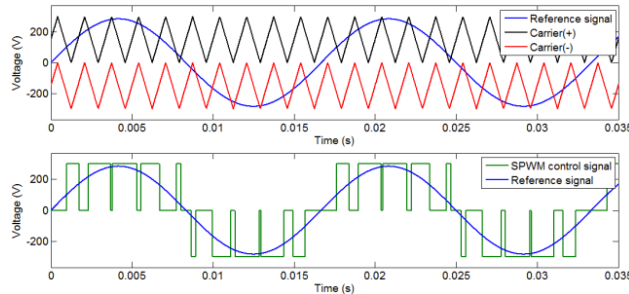

Figure 3: Three-level SPWM control method

Table 1: Sequences of control vectors

S	[S11, S12, S13, S14]	V _{ao}
1	[1 1 0 0]	V _{ao}
2	[0 1 1 0]	0
3	[0 0 1 1]	V _{ao}

The same as the reference voltage V_{ra} frequency.

The inverter output voltages are written as follow (1)

$$\begin{cases} V_{ao} = \frac{1}{3} (V_{ab} - V_{ca}) \\ V_{bo} = \frac{1}{3} (V_{bc} - V_{ab}) \\ V_{co} = \frac{1}{3} (V_{ca} - V_{bc}) \end{cases} \quad (1)$$

Modulation index (m_a) is defined by (2)

$$m_a = \frac{A_r}{(n - 1)A_c} \quad (2)$$

Where A_r and A_c are the peak to peak value of V_{ao} And V_c respectively.

The Higher Level Control strategy

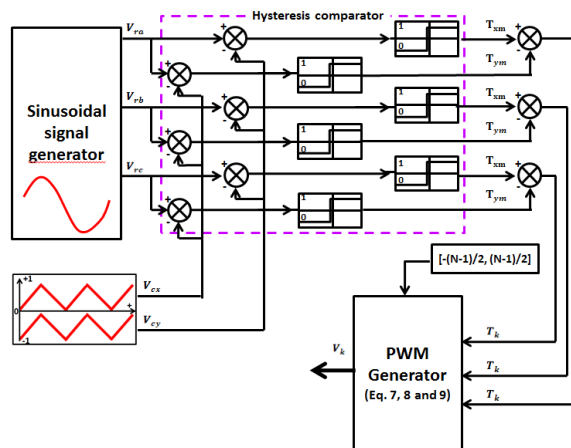

Figure 4: Principle SPWM multilevel inverter control

The previous study for the *three-level* voltage inverter is now extended to higher level inverters. For an *n-level* inverter, it is possible to determine the number of components that are needed per arm (number of switches, diodes, carrier, etc).

Numbers of inverter components calculation:

Define Seq as the number of commutation sequence possibilities. S is the number of secondary voltage sources. K stands for the number of switches per phase. D is the number of diodes loop including the diode switches per phase. C represents the magnitude of the voltage across each capacitor and P is the number of carriers. The following equations provide how these quantities are calculated and table 2 shows the values for several multilevel inverters.

$$\begin{cases} S_{eq} = 2^{(n+1)} \\ S = P = n - 1 \\ K = 2(n - 1) \\ D = 4n - 6 \\ C = \frac{V_{dc}}{n - 1} \end{cases} \quad (3)$$

Table 2 : Sequence of the control Vectors

N	Seq	S=P	K	D	C
3	16	2	4	6	Vdc/2
5	64	4	8	14	Vdc/4
7	256	6	12	22	Vdc/6

Calculation of carrier:

A bipolar sawtooth carrier is illustrated at Figure 6. The voltages Vcx and Vcy have the expression given by equation (4):

$$\begin{cases} V_{cx} = \sum_{x=2}^h V_{cx-1} + 1 \\ V_{cy} = \sum_{y=-2}^{-h} V_{cy-1} - 1 \end{cases} \quad (4)$$

Calculation of reference voltages:

The balanced three-phase reference voltage is given by(5):

$$V_r : \begin{cases} V_{ra}(t) = A_r \sin(2\pi f_r t) \\ V_{rb}(t) = A_r \sin\left(2\pi f_r t - \frac{2\pi}{3}\right) \\ V_{rc}(t) = A_r \sin\left(2\pi f_r t - \frac{4\pi}{3}\right) \end{cases} \quad (5)$$

Calculation of the comparator:

The comparator uses the reference and carrier signals to generate a binary signal according to the following equation:

$$\left\{ \begin{array}{l} \text{If } V_r \geq V_{cx} \Rightarrow T_{xm} = 1 \\ \text{or} \\ \text{If } V_r < V_{cx} \Rightarrow T_{xm} = 0 \\ \text{and} \\ \text{If } V_r \leq V_{cy} \Rightarrow T_{ym} = 1 \\ \text{or} \\ \text{If } V_r > V_{cy} \Rightarrow T_{ym} = 0 \end{array} \right. \quad (6)$$

Calculation of the adder:

The parameter K_T is the difference between T_{xm} and T_{ym} . It is therefore calculated as follows.

$$T_k = T_{xm} - T_{ym} \quad (7)$$

Calculation of inverter control vectors:

The generation of the pulse vector that control the inverter is very important. The pulse vector can be generated by applying the $X7$ vector for each MT according equation (8). The inverter output voltage V_k is given by equation (9).

$$\text{If } T_k = \frac{n-1}{2} - i \Rightarrow \left\{ \begin{array}{l} G_1 = [0 \dots 0 \ 1 \dots 1] \\ G_2 = [1 \dots 0 \ 0 \dots 1] \\ G_3 = [1 \dots 0 \ 0 \dots 1] \\ \dots \\ G_n = [1 \dots 1 \ 0 \dots 0] \end{array} \right. \quad (8)$$

$$V_k = \frac{h-i}{n-1} V_{dc} \quad (9)$$

Simulink Circuit

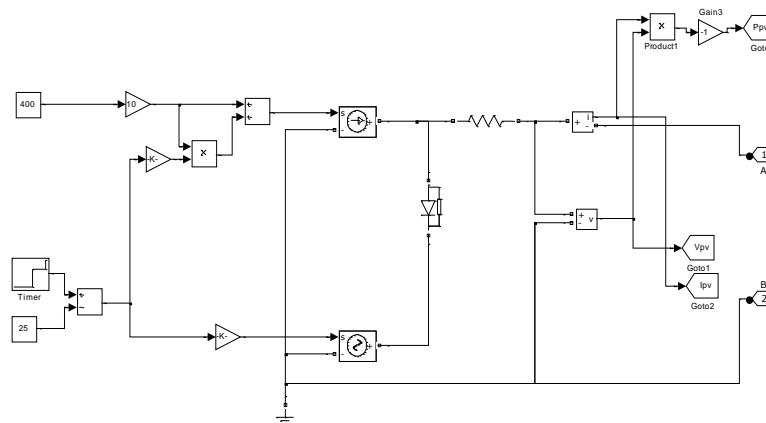

Figure 5: Simulink Diagram of PV Array

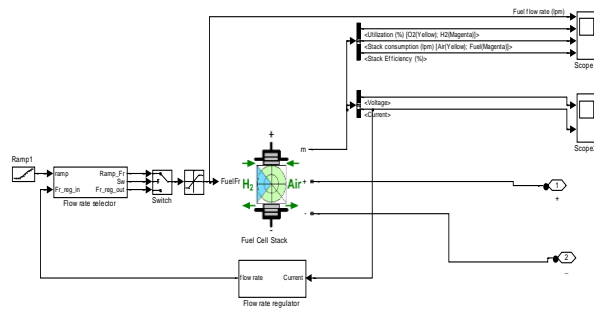

Figure 6: Simulink Diagram of Fuel Cell

Simulation Results

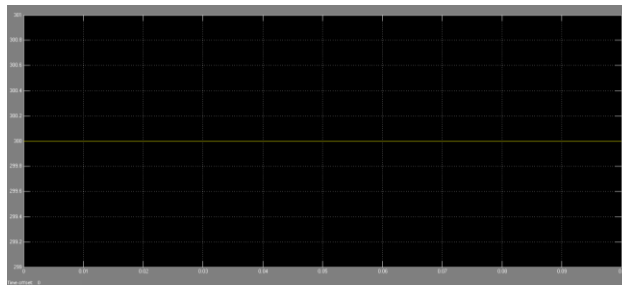

Figure 7: Input Voltage

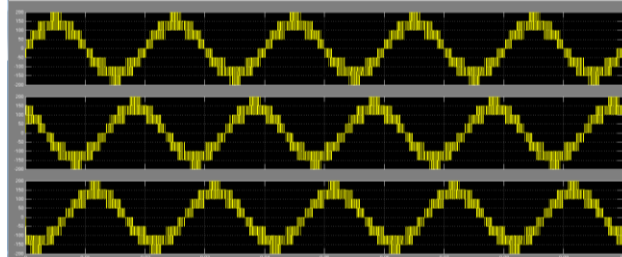

Figure 8 : Multilevel output Voltage without filter

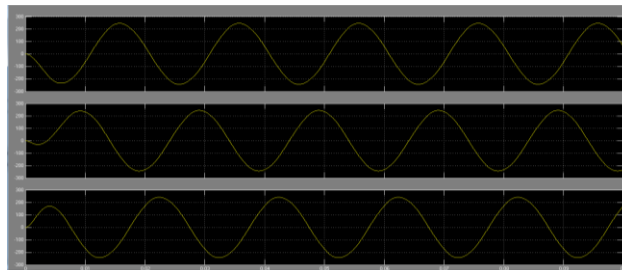

Figure 9 : Multilevel output voltage with filter

Total Harmonic Distraction Analysis of Multilevel Inverter

The main criterion for assessing the quality of the voltage delivered by an inverter is the Total Harmonic Distortion (THD). This section will be devoted to analysing the inverters performance according to their number level. Level three, seven inverters will be considered. The goal is to see if the low order harmonics amplitude will decrease when the number of level increases. The inverter is usually followed by a lowpass filter since higher frequency harmonics are easy to filter. This means that the performance of multilevel inverters can be improved by cancelling or reducing lower order harmonics. Lower order harmonics generate the most important currents when an inductive load is used.

The THD is a ratio between the Root Mean Square (RMS) of the harmonics and the fundamental signal. For an inverter that has a fundamental output voltage V_1 and harmonics V_2, V_3, \dots , we define the THD as follows:

$$THD = \frac{\sqrt{\sum_{k \geq 2}^N V_k^2}}{V_1} \tag{10}$$

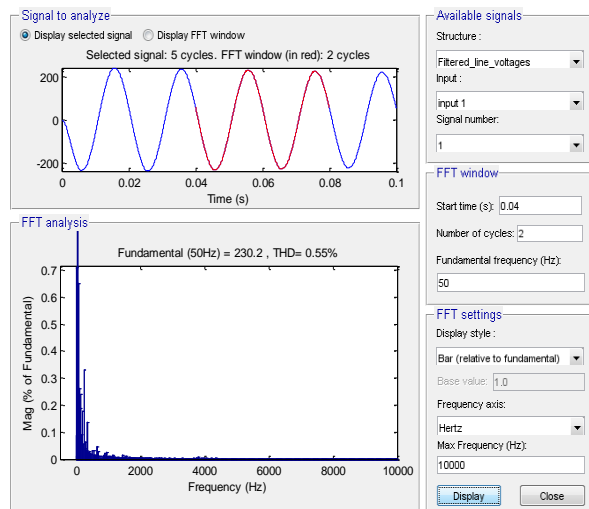

Figure 10: THD of the Multilevel Inverter Voltage (0.55)

CONCLUSION

In this paper, a general multilevel SPWM control algorithm for n -level inverter has been modelled and simulated using Matlab®/Simulink. This algorithm can generate automatically SPWM pulses for any level of inverter by changing only a parameter n which is the number of inverter level. Simulation of 3, 9, and fifteenlevel inverter connected to induction motor has been performed and the generated signals THD is analysed. The system is supplied by a PV panel and batteries bank. That gives energy autonomy to the system. Simulation results give a better quality of stator current in terms of low harmonics, thus reducing the adverse effects on of the machine life and eventually the electrical network which supplies it. Base to THD analyse for three different index of modulation, we have also highlighted that at fifteen-level, the harmonics are very low. These latter can be easily eliminated with a simple low-pass filter. So it is not necessary to continue increasing the inverter level.

REFERENCES

1. R. Teodorescu , F. Beaabjerg , “Multilevel converters - A survey”, Proc. EPE'99, pp. 1999.
2. Z. Yan, M. Jia, "An Integration SPWM Strategy for High- Frequency Link Matrix Converter With Adaptive Commutation in One Step Based on De-Re-Coupling Idea ", Industrial Electronics, IEEE Transactions on, Vol. 59 , pp. 116-128, 2012.
3. Wu, F.J., "Single-phase three-level SPWM scheme suitable for implementation with DSP", Electronics Letters, Vol. 47, pp. 994- 996, 2011
4. D.G. Holmes, and P.M. Brendan, “Opportunities for harmonic cancellation with carrier based PWM for two level and multilevel cascaded inverters”, IEEE Trans. on Industry Applications, Vol.37, No.2, pp. 574-582, 2001.
5. L. Li, C. Dariusz, and Y. Liu, “Multilevel space vector PWM technique based on phase-shift harmonic suppression” Applied Power Electronics Conference and Exposition (APEC), Vol.1, pp. 535-541, 2000.
6. L. M. Tolbert, "Multilevel Converters for Large Electric Drives", IEEE Trans. on Ind. Application, Vol. 35, pp. 36-44, 1999.
7. L. Tian, S. Qiang, L. Wenhua, C. Yuanhua, and L. Jianguo, “FPGAbased universal multilevel space vector modulator” in Proc. IECON 32nd Annu. Conf., pp. 745–749, 2005.
8. D. Ning-Yi, W. Man-Chung, and H. Ying-Duo, “Application of a three level NPC inverter as a three-phase four-wire power 22 quality compensator by generalized 3DSVM” IEEE Trans. Power Electron., vol. 21, no. 2, pp. 440–449, Mar. 2006.
9. M. A. Tankari, M.B.Camara, B. Dakyo, C. Nichita, “Ultracapacitors and Batteries control for Power Fluctuations mitigation in Wind-PV-Diesel Hybrid System”, Int. Conf. EVER'11, Monte-Carlo, Mars 2011.
10. M. A. Tankari, M.B.Camara, B. Dakyo, “DC-bus Voltage Control in Multi-sources System – Battery and Supercapacitors”, the 37th Annual Conf. of the IEEE Industrial Electronics Society IECON, Melbourne - Australia, Nov. 2011.